



DriMaster II HiFlo Stainless Steel Upholstery Tool Owner's Manual

HydraMaster North America, Inc.
11015 47th Avenue West, Mukilteo, Washington 98275

MAN-33278 Rev. 2 February 15, 2013
(182-803)

No part of this manual may be reproduced or used in any form or by any means (i.e. graphic, electronic, photocopying or electronic retrieval systems) without the express written permission of HydraMaster. Specifications and information in this document are subject to change without prior notice. All rights reserved. © 2013 HydraMaster

This page intentionally left blank.

Table of Contents

| | |
|---|------------------|
| GENERAL INFORMATION..... | SECTION 1 |
| Contact Information..... | 1-2 |
| Warnings, Cautions and Notices..... | 1-3 |
| OPERATING INSTRUCTIONS..... | SECTION 2 |
| Optional Accessory Handle Assembly..... | 2-1 |
| Begin Cleaning..... | 2-2 |
| TOOL MAINTENANCE..... | SECTION 3 |
| Removing and Re-installing the Clear Window Cover..... | 3-1 |
| Cleaning the Solution Bar Jet..... | 3-2 |
| Cleaning the Filter Cartridge and Orifice Plate..... | 3-3 |
| ASSEMBLIES AND PARTS LISTS..... | SECTION 4 |
| DriMaster II HiFlo Stainless Steel Upholstery Tool Assembly Parts List..... | 4-3 |
| Accessory Handle Assembly Parts List..... | 4-4 |
| Hide-A-Hose Stainless Steel Hose Assembly Parts List..... | 4-7 |
| HOW TO ORDER PARTS..... | SECTION 5 |
| Warranty Parts Orders..... | 5-1 |
| Parts Orders..... | 5-1 |
| Emergencies..... | 5-1 |
| WARRANTY INFORMATION..... | SECTION 6 |

List of Figures

| | |
|---|---|
| Figure 1-1. DriMaster II HiFlo Stainless Steel Upholstery Tool | 1 |
| Figure 1-2. Optional Accessory Handle Attached to Tool | 1 |
| Figure 2-1. Remove Tool Screws | 1 |
| Figure 2-2. Attach Accessory Handle | 1 |
| Figure 2-3. Attach Solution Hose and Adjust Water Volume | 2 |
| Figure 2-4. Turning Knob to “HiFlo” Position Forms Sheet of Water Across Bar Jet..... | 3 |
| Figure 3-1. Remove Tool from Hose | 1 |
| Figure 3-2. Remove Solution Control Knob | 1 |
| Figure 3-3. Remove All Screws on Tool | 1 |
| Figure 3-4. Separate Tool in Half | 1 |
| Figure 3-5. Re-install Clear Window Cover..... | 2 |
| Figure 3-6. Clean the Solution Bar Jet..... | 2 |
| Figure 3-7. Disassemble Solution Quick Connect..... | 3 |
| Figure 3-8. Remove Filter Cartridge and Plate Orifice | 3 |
| Figure 3-9. Re-assemble Solution Quick Connect..... | 3 |
| Figure 4-1. DriMaster II HiFlo Stainless Steel Upholstery Tool Assembly - Overview | 1 |
| Figure 4-2. DriMaster II HiFlo Stainless Steel Upholstery Tool Assembly - Parts View | 2 |
| Figure 4-3. Accessory Handle Assembly..... | 4 |
| Figure 4-4. Hide-A-Hose Stainless Steel Hose Assembly - Parts View 1 of 2 | 5 |
| Figure 4-5. Hide-A-Hose Stainless Steel Hose Assembly - Parts View 2 of 2 | 6 |

1 - General Information

Congratulations on purchasing the very latest in upholstery cleaning technology.

The patented DriMaster II HiFlo Stainless Steel Upholstery Tool, shown in Figure 1-1, is perfect for cleaning upholstery, fabric and stairs. Because of its Jetless Cleaning Technology, it has no trigger valve, no spray jet and never needs a separate dry pass.*

The tool's new design incorporates light weight, extremely durable materials, giving the tool increased levels of strength and comfort.

The DriMaster II HiFlo Stainless Steel Upholstery Tool accommodates high volume jobs where production rate is important.

It is capable of solution flow rates for jobs that require a flushing action which makes the tool particularly efficient for stair cleaning.

An optional accessory handle, shown attached to the tool in Figure 1-2, is available to increase comfort on long cleaning jobs.

We trust that you will enjoy many years of reliable upholstery cleaning with the DriMaster II HiFlo Stainless Steel Upholstery Tool.

NOTICE

The DriMaster II HiFlo Stainless Steel Upholstery Tool can be used with a variety of HydraMaster cleaning systems.



Figure 1-1. DriMaster II HiFlo Stainless Steel Upholstery Tool



Figure 1-2. Optional Accessory Handle Attached to Tool

* U.S. Patent No. 6,243,914; 7,070,662; RE39,623; D590,111
New Zealand Patent No. 549645
Other U.S. and Foreign Patents Pending



CONTACT INFORMATION

If you have any questions regarding the operation, maintenance or repair of this tool, please contact your local distributor.

To find a local distributor, please visit our website at <http://www.hydramaster.com/owners/locate/index.asp>.

If your question cannot be resolved by your distributor or by the information within this manual, you may contact HydraMaster direct using the following phone numbers.

| HOURS | TELEPHONE NUMBERS | E-MAIL ADDRESSES |
|---|--|---|
| Monday-Friday 7:00 a.m. to 5:00 p.m. Pacific Time | Technical Support (425) 775-7275 FAX : (800) 426-4225 | Technical Support techsupport@hydramaster.com |
| | Customer Service/Parts (425) 775-7276 FAX: (425) 771-7156 | Customer Service/Parts parts@hydramaster.com |

When calling your distributor, be sure to reference the serial number and date of purchase.

FOR YOUR REFERENCE:

Serial No. _____

Date of Purchase: _____

Purchased From (Distributor): _____

WARNINGS, CAUTIONS AND NOTICES

⚠ WARNING

HydraMaster uses this WARNING symbol throughout the manual to warn of possible injury or death.

CAUTION

This CAUTION symbol is used to warn of possible equipment damage.

NOTICE

This NOTICE symbol indicates that federal or state regulatory laws may apply, and also emphasizes supplemental information.



This page intentionally left blank.

2 - Operating Instructions

Your DriMaster II HiFlo Stainless Steel Upholstery Cleaning Tool has been engineered using the latest and most sophisticated technology available to produce the finest upholstery cleaning results possible. Despite this, it remains only a tool of the upholstery cleaning trade and can produce only as good a job as the person operating it.

HydraMaster strongly recommends attending an Institute of Inspection, Cleaning and Restoration Certification (IICRC) approved Upholstery Cleaning course as soon as possible and to always follow the IICRC guidelines when cleaning.

OPTIONAL ACCESSORY HANDLE ASSEMBLY

The DriMaster II HiFlo Stainless Steel tool can be equipped with an optional accessory handle (purchased separately) to increase comfort and control during difficult or extended repetitive use of the upholstery tool.

1. Remove the two screws, nuts, and washers found on the handle grip portion of the tool (Figure 2-1). These parts will be reused in fastening the handle.



Figure 2-1. Remove Tool Screws

2. Attach the accessory handle as shown in Figure 2-2. The original shorter screws, nuts, and washers are used on the upper handle. The longer supplied screws, nuts and washers are used to connect the handle to the tool body.



Figure 2-2. Attach Accessory Handle

BEGIN CLEANING

⚠ WARNING

Do not use the DriMaster II HiFlo Stainless Steel Upholstery Tool on a machine exceeding 14" Hg vacuum and 500 psi solution pressure. Personal injury could result.

1. Attach the solution hose to the solution quick connect. A 1 ½" - 2" vacuum hose can be attached to the vac hose manifold (see Figure 2-3).

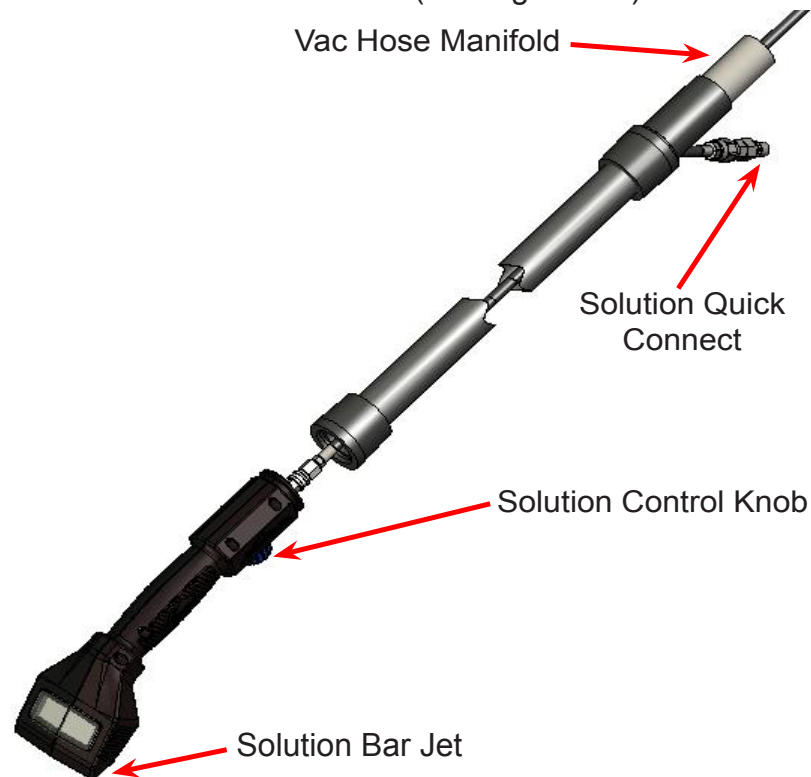

Figure 2-3. Attach Solution Hose and Adjust Water Volume

2. Adjust the water volume by turning the solution control knob. Turning the knob counterclockwise increase the water volume; turning the knob clockwise decreases the water volume. The amount of water volume you need will vary with the type of machine you are cleaning with and the type of material you are cleaning.
3. To begin adjustment, make sure the cleaning machine is running and both vacuum and solution hoses are connected.
4. Slowly open the solution control knob until water is flowing across the entire bar jet (without overspray).

When the solution knob is turned toward the “HiFlo” position, the water will form a sheet across the solution bar jet (see Figure 2-4)

NOTICE

The amount of vacuum and pressure produced by your machine will determine the overspray on the solution bar jet. The patented solution bar jet makes a trigger valve unnecessary.

⚠ WARNING

Do not touch the solution bar jet during operation or immediately afterward; doing so may cause severe burns!

CAUTION

When cleaning stairs, do not allow the tool to come into contact with the tack strip along the edges of the stairs. The tool’s cleaning surface will be damaged by the tack strip. Equipment damage such as this is not covered by warranty.

NOTICE

It may be necessary to periodically clean the inside of the tool, hose and manifold. Debris can build up over time, restricting the vacuum flow (see Figure 3-6).



Figure 2-4. Turning Knob to “HiFlo” Position Forms Sheet of Water Across Bar Jet



This page intentionally left blank.

3 - Tool Maintenance

REMOVING AND RE-INSTALLING THE CLEAR WINDOW COVER

1. Remove vacuum hose cuff from DriMaster II HiFlo Stainless Steel Upholstery Tool and disconnect the solution hose quick connect as shown in Figure 3-1.

NOTICE

Lightly heating the “cuff” with a heat gun will make the cuff easier to remove and install.

2. Remove the solution control knob by removing the 8/32” Allen head screw as shown in Figure 3-2.



Figure 3-1. Remove Tool from Hose



Figure 3-2. Remove Solution Control Knob

3. Loosen, but do not remove, the valve retention nut (see arrow in Figure 3-3).
4. Remove all screws from both sides of the tool (see Figure 3-3) and carefully separate the tool halves (see Figure 3-4).



Figure 3-3. Remove All Screws on Tool

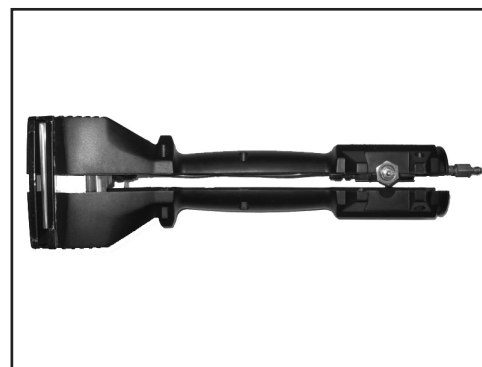

Figure 3-4. Separate Tool in Half

5. Slide the clear window cover off of the tool body.
6. To re-install the clear window cover, slide it into one half of the tool body (see Figure 3-5). Then slide the other half of the body into the window.

The clear window has grooves on either side that slide onto the edges of the cutouts in the tool bodies.



Figure 3-5. Re-install Clear Window Cover

NOTICE

The wear plates must be aligned and slid onto the tool half at the same time as the cover.

CAUTION

The window cover may come out if not installed properly.

7. Continue to assemble the two halves of the tool together, with the clear window being captured in the cutouts. Careful attention must be paid when sliding the two body halves together.
8. Re-install the body screws.
9. Apply Loctite® 245 to the threads of the valve.
10. Tighten the valve retention nut. Do not overtighten.
11. Apply Loctite 245 to the valve control knob set screw. Tighten set screw securely.

CLEANING THE SOLUTION BAR JET

The solution bar jet needs to be cleaned with a .020" feeler gauge.

1. Slide the feeler gauge into the small slot.
2. Gently slide the gauge back and forth to clear any debris from the opening (see Figure 3-6).

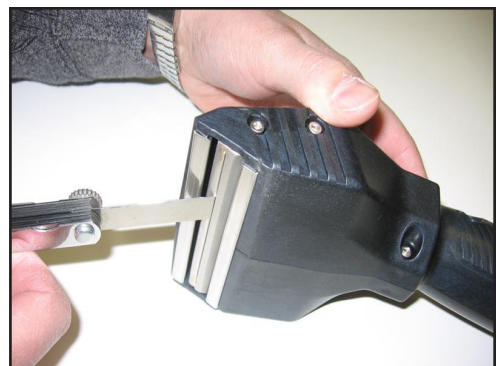

Figure 3-6. Clean the Solution Bar Jet

CAUTION

Use only a feeler gauge to clean the slot in the bar jet. Use of any other implement (paper clip, knife blade) may damage the opening and seriously reduce the cleaning effectiveness of the upholstery tool.

NOTICE

HydraMaster recommends you clean the filter cartridge and orifice plate on a periodic basis to eliminate hard water deposit buildup. Both components are conveniently located in the solution quick connect subassembly.

Disassemble the solution quick connect to gain access to the filter cartridge and orifice plate (see Figure 3-7 and Figure 3-8).

CLEANING THE FILTER CARTRIDGE AND ORIFICE PLATE

1. Remove the filter cartridge and orifice plate, place them in a cup full of white vinegar and soak for 30 minutes.
2. Clean the orifice plate's opening with a wooden skewer or similar tool such as a plastic pick.

CAUTION

Do not use a metal object to clean the opening of the orifice plate; doing so can damage the plate.

3. Remove both parts from the vinegar and thoroughly rinse them with clear water.
4. Re-assemble the solution quick connect, re-installing the filter cartridge and orifice plate in the proper order (see arrows in Figure 3-9).

CAUTION

Do not operate the DriMaster II HiFlo Stainless Steel Upholstery Tool without the orifice plate. If you do not properly re-install the orifice plate in the solution quick connect (see Figure 3-9), equipment damage could result. Such equipment damage is not covered by warranty.



Figure 3-7. Disassemble Solution Quick Connect

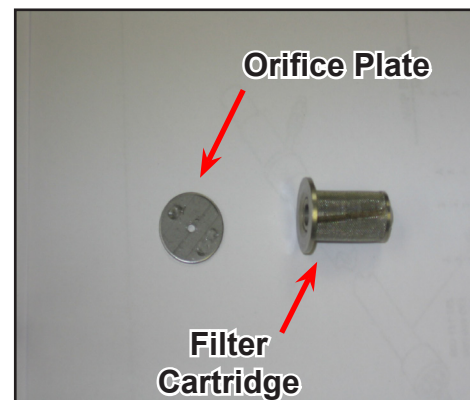

Figure 3-8. Remove Filter Cartridge and Plate Orifice

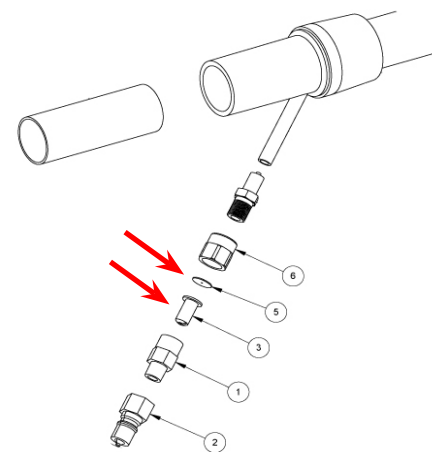

Figure 3-9. Re-assemble Solution Quick Connect



This page intentionally left blank.

4 - Assemblies and Parts Lists

Figure 4-1. DriMaster II HiFlo Stainless Steel Upholstery Tool Assembly - Overview



**Figure 4-2. DriMaster II HiFlo Stainless Steel Upholstery
Tool Assembly - Parts View**
7332 Rev. A

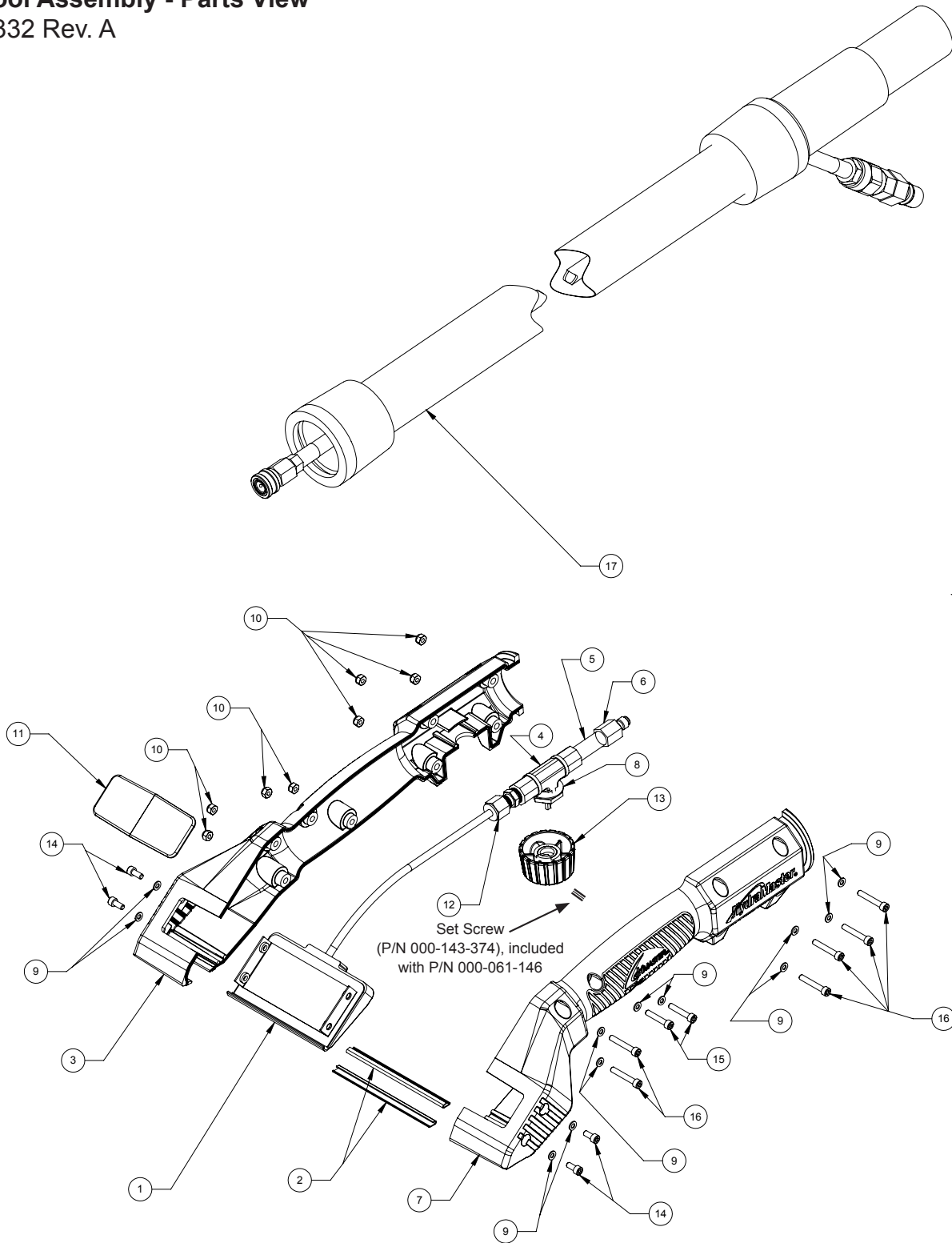

DriMaster II HiFlo Stainless Steel Upholstery Tool Assembly Parts List

| Item | Part Number | Description | Qty |
|------|-------------|--|-----|
| 1 | 000-076-088 | Jet, DriMaster S/S HiFlo Bar Assembly | 1 |
| 2 | 000-105-533 | Plate, Wear DriMaster | 2 |
| 3 | 000-061-138 | Handle, Handpiece, Left, DriMaster HiFlo | 1 |
| 4 | 000-169-222 | Valve, Ball S/S | 1 |
| 5 | 000-052-782 | 1/8" NPT X 1.5 S. S. | 1 |
| 6 | 000-052-783 | Quick Disconnect, Male 1/8" NPT | 1 |
| 7 | 000-061-139 | Handle, Handpiece, Right, DriMaster HiFlo | 1 |
| 8 | 000-174-168 | Washer, Flat Mil Spc | 1 |
| 9 | 000-174-167 | Washer, Flat, .248 O.D. X .128 I.D. X .029 Thk | 12 |
| 10 | 000-094-063 | Nut, Nylon Lock 6-32 | 8 |
| 11 | 000-041-445 | Cover, DriMaster HiFlo, Window | 1 |
| 12 | 000-052-781 | 1/8" NPT X .1875" O.D. | 1 |
| 13 | 000-061-146 | Assembly, Knob Custom Insert With Label | 1 |
| 14 | 000-143-576 | Capscrew, Socket Head, 6-32 X 5/16 | 4 |
| 15 | 000-143-577 | Capscrew, Socket Head, 6-32 X 3/4 | 2 |
| 16 | 000-143-578 | Capscrew, Socket Head, 6-32 X 7/8 | 6 |
| 17 | 000-068-810 | Hose, Hide-A-Hose S/S Assembly | 1 |

Figure 4-3. Accessory Handle Assembly
6958 Rev. B

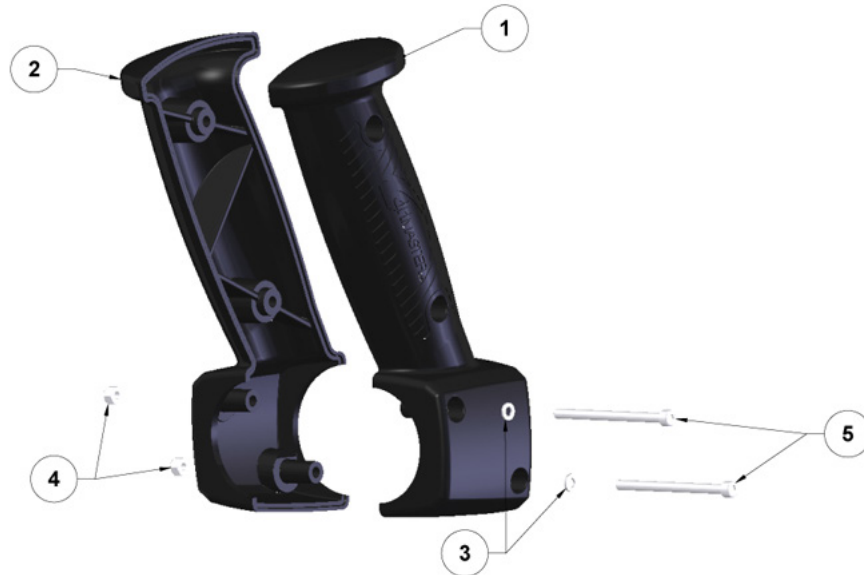

Accessory Handle Assembly Parts List

| Item | Part Number | Description | Qty |
|------|-------------|--|-----|
| 1 | 000-061-142 | Handle, Accessory, Right | 1 |
| 2 | 000-061-141 | Handle, Accessory, Left | 1 |
| 3 | 000-174-167 | Washer, Flat, 0.248" O.D. x 0.128" I.D. x 0.029" Thk | 2 |
| 4 | 000-094-063 | Nut, #6-32 Nylock | 2 |
| 5 | 000-143-579 | Screw, #6-32UNC x 2" Lg. Socket Head | 2 |

P/N 000-164-030 Allen wrench also included with the Accessory Handle Assembly.

Figure 4-4. Hide-A-Hose Stainless Steel Hose Assembly - Parts View 1 of 2
7331 Rev. D

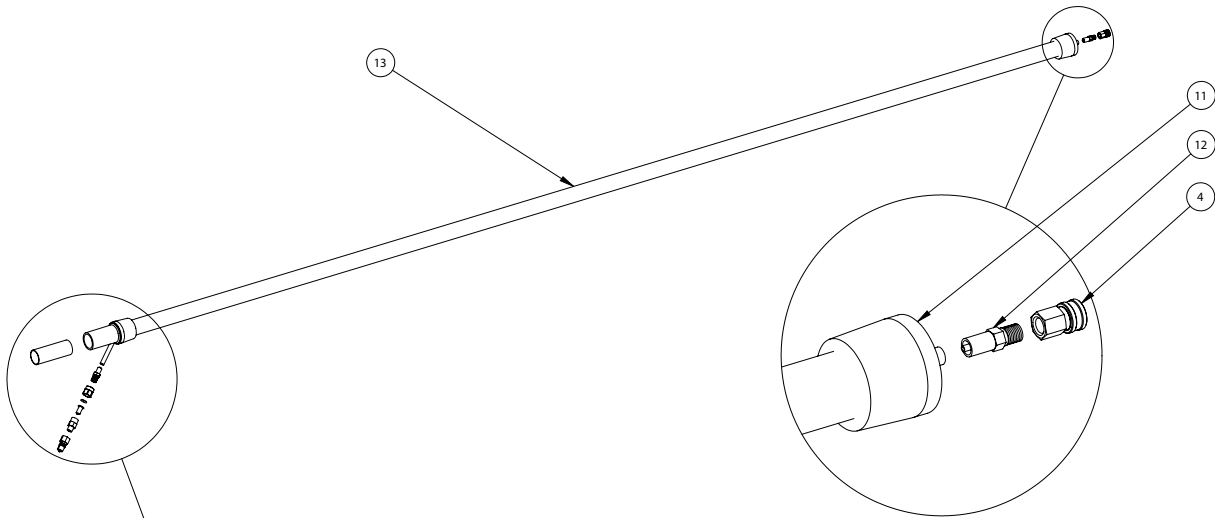

See Figure 4-5 for details

Figure 4-5. Hide-A-Hose Stainless Steel Hose Assembly - Parts View 2 of 2
7331 Rev. D

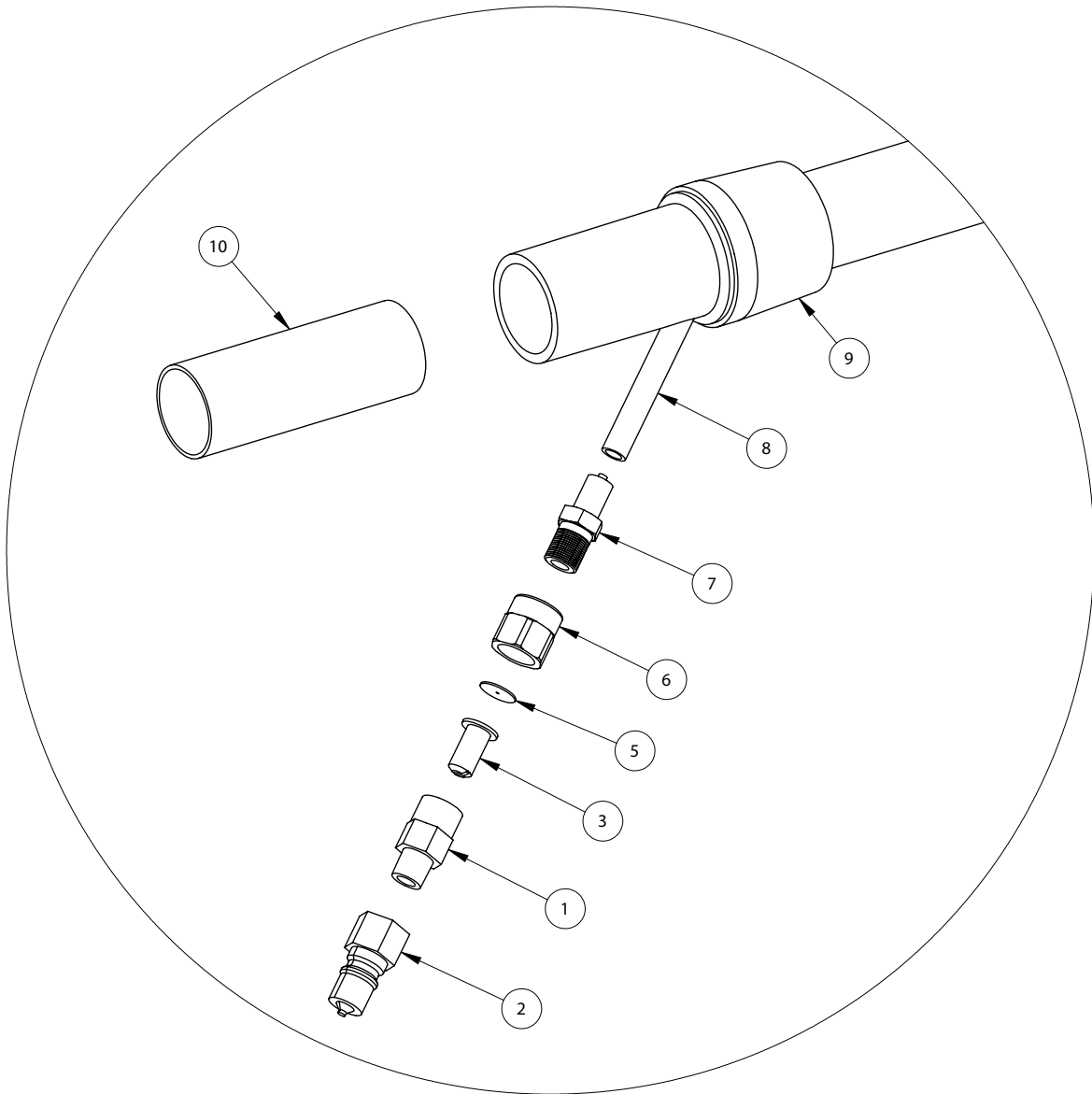

Hide-A-Hose Stainless Steel Hose Assembly Parts List

| Item | Part Number | Description | Qty |
|------|-------------|--------------------------------------|-----|
| 1 | 000-052-803 | Housing, 1/4" S/S. Filter | 1 |
| 2 | 000-052-516 | Quick Connect, 440 Male W/ Viton Std | 1 |
| 3 | 000-049-253 | Filter Cartridge, 1/4" S/S | 1 |
| 4 | 000-052-805 | Quick Connect, Female, 1/8" - Open | 1 |
| 5 | 000-180-024 | Orifice, Plate 0.067" | 1 |
| 6 | 000-052-804 | Adapter, S/S. Jet X 1/4" FNPT | 1 |
| 7 | 000-052-811 | Insert, 1/8" Hose X 1/4" MNPT S/S | 1 |
| 8 | 000-068-811 | Hose, 1/8" USP 540n-2 | 1 |
| 9 | 000-052-807 | Cuff - Solution Hose 1/4" Thru | 1 |
| 10 | 000-125-248 | Tube, 1.5" S/S - Hide-A-Hose | 1 |
| 11 | 000-052-806 | Swivel Cuff - Half | 1 |
| 12 | 000-052-810 | Insert, 1/8" Hose X 1/8" MNPT S/S | 1 |
| 13 | 000-068-036 | Hose - Gray, 1.5" Vac | 1 |



This page intentionally left blank.

5 - How to Order Parts

From time to time, cleaning equipment may wear out or malfunction. To obtain a proper diagnosis of your malfunction, and to order warranty replacement parts or arrange for repairs, it is important that you proceed in the following manner:

WARRANTY PARTS ORDERS

1. Call the local distributor where you purchased your equipment and ask for the Service Department.
2. Have the following information ready:
 - a. Equipment Model
 - b. Date of Purchase
 - c. Description of Malfunction
3. Once it has been determined which parts are needed to correct the problem with your tool, make arrangements with your distributor to either perform the repairs or ship the parts to you.

PARTS ORDERS

Call your local distributor. In most instances, they either stock or have access to parts through a regional service center.

EMERGENCIES

If, for any reason, your distributor is unable to supply you with the necessary parts, they may call us and arrange for expedited shipping.

HydraMaster sells parts only through authorized distributors and service centers.

We shall always endeavor to be fair in our evaluation of your warranty claim, and shall provide you with a complete analysis of our findings.



This page intentionally left blank.



6 - Warranty Information

All parts of the DriMaster II HiFlo Stainless Steel Upholstery Tool are warranted against defects for 1 year.

Freezing, hard water, the use of unapproved solvents and/or abuse will void the warranty.

HydraMaster warranty covers only defective materials and/or workmanship for the period listed. **Labor and/or diagnostic reimbursement is specifically excluded.**

If you have moved to a new area or have purchased a used machine and need information regarding your local distributor, call HydraMaster at (425) 775-7272 or email us at: custsvc@hydramaster.com.



This page intentionally left blank.